

# 产品尺寸图 (DIMENSION)

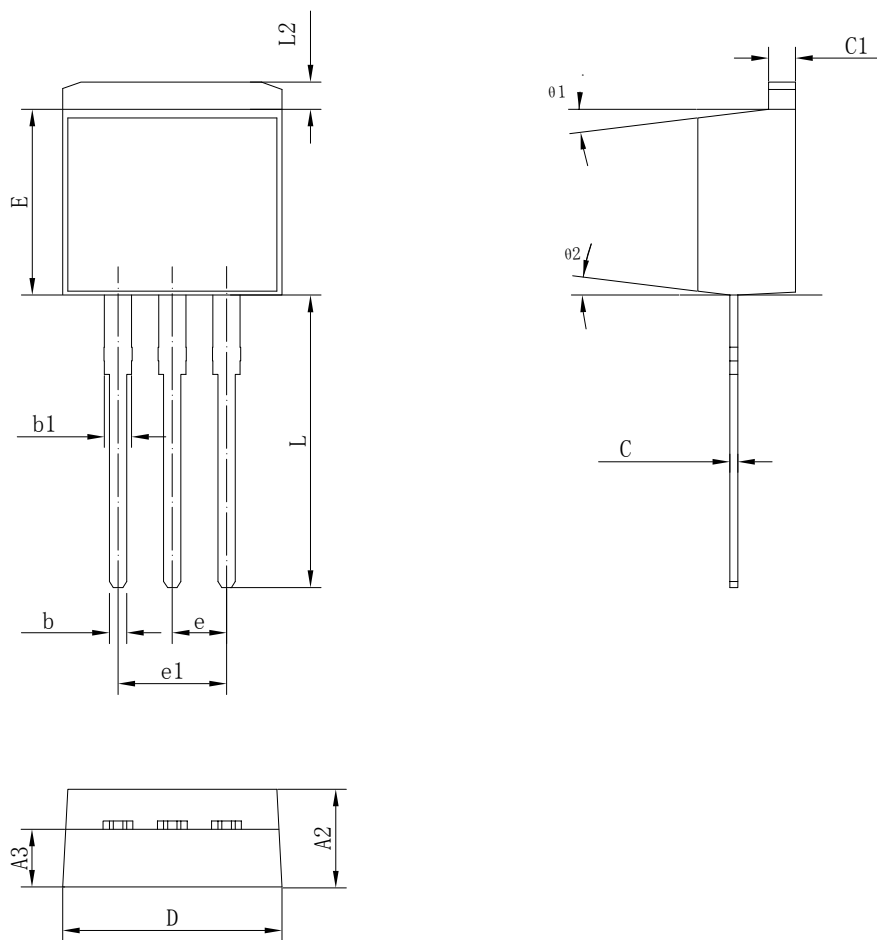

symbol	Dimensions In Millimeters			Dimensions In Inches		
	Min	Nom	Max	Min	Nom	Max
A2	4.06	4.57	4.83	0.160	0.180	0.190
A3	2.40	2.70	2.95	0.094	0.106	0.116
b	0.50	0.81	1.00	0.020	0.032	0.039
b1	1.14	1.27	1.52	0.044	0.050	0.060
C	0.33	0.40	0.47	0.013	0.016	0.019
C1	1.14	1.27	1.40	0.045	0.050	0.055
D	9.66	10.16	10.54	0.380	0.400	0.415
E	8.38	8.70	9.66	0.330	0.343	0.380
e	2.29	2.54	2.79	0.090	0.100	0.110
e1	4.83	5.08	5.33	0.190	0.200	0.210
L	13.38	13.68	13.98	0.527	0.539	0.550
L2	1.17	1.27	1.37	0.046	0.050	0.054
θ 1	6°	7°	8°	6°	7°	8°
θ 2	6°	7°	8°	6°	7°	8°

# FSMC

图名 NAME	T0-262-3		图号 DWG. NO.	DD0037	SH 1 OF 1
材质 MATERIAL	Cu		REV.	F	
单位 UNITS	mm [INCH]	核准 APPROVE	审核 CHECKED	制图 DRAWN	 第三角法
日期 DATE	2020.04.20				
比例 SCALE	N. T. S.				